

UM-11 Series

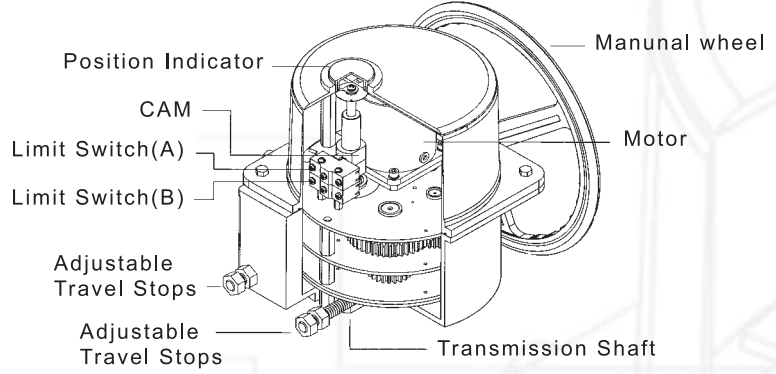

Weight : 34 kg



Power	Specification		Speed(sec)		Output Troque Kgf-cm		
	110VAC	220VAC	AC	DC	110VAC	220VAC	24VDC
100W	0.92A	0.34A	65	N/A	15000	14500	N/A

The Size Of Valve	
Flanged Ends	Butterfly Valve
10" ~ 12"	16" ~ 18"

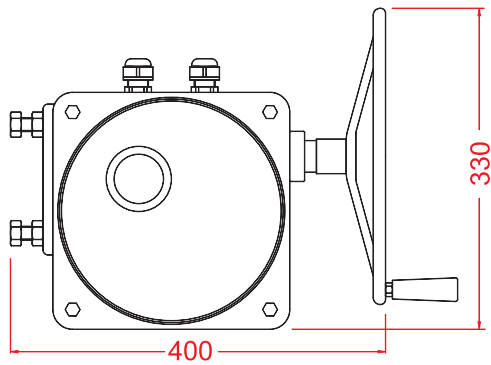

(mm)

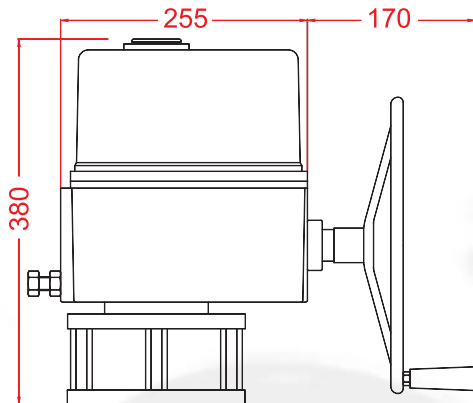

Mounting pattern is depending on valve

